

## #14423 Thompson Sideboard Kit

### Step-by-step assembly instructions

Copyright miniatures.com 2024

#### PARTS LIST:

Back  
Side (2)  
Top  
Bottom  
Shelf  
Divider  
Inner Trim  
Outer Trim  
Door



#### GENERAL INSTRUCTIONS

- Identify and inspect all parts using the Parts List.
- Thoroughly read the directions before starting.
- Set up a dedicated work area to avoid the need to unpack, repack, or move the project frequently.
- Use a clean, level, and dry work surface protected from glue spills.
- Dry fit the parts using masking tape to ensure everything aligns correctly before permanent assembly.

## Assembly Instructions

1. Lay the **Back** flat and glue the **Sides** and **Bottom**, aligning tab and slot patterns to form the box. Ensure edges are flush and let the glue set.
2. Attach the **Top** flush with the **Back** and **Sides**.
3. Glue the **Shelf** in either interior corner, level, and flush at the front, then let set.
4. Attach the **Divider** to the **Shelf**, **Back**, and **Top**, keeping it flush with the front.
5. Glue the thinner **Inner Trim** to the front edge, removing any excess glue.
6. Let dry, then place (do not glue) the **Door** inside the **Inner Trim**, orienting the handle as desired.
7. Attach the thicker **Outer Trim** over the **Inner Trim**, flush with all edges. Clean glue from the track to ensure the **Door** slides smoothly.
8. Allow the assembly to dry completely.

Assembly is now complete. Enjoy finishing as desired.

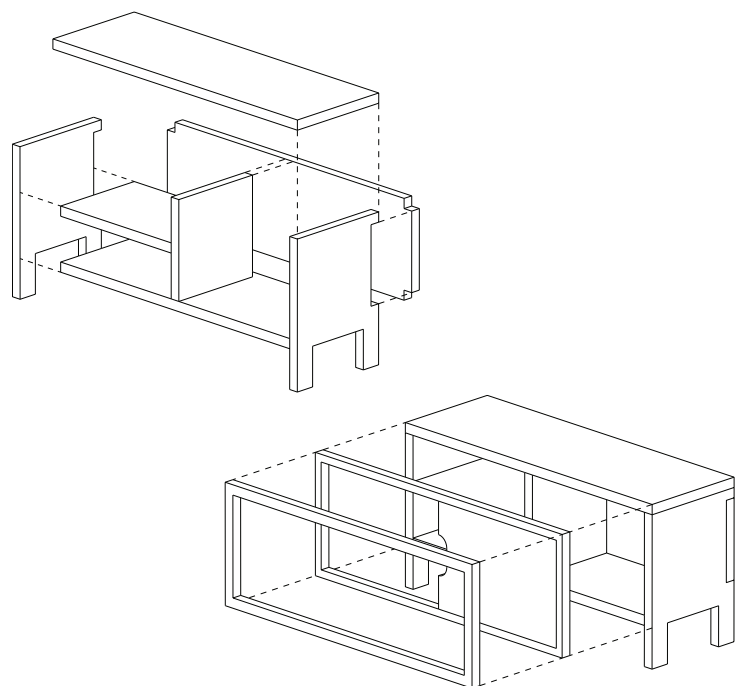

# Parts Diagram

Note: Not to scale

